

INTEGRATED DIAGNOSTICS OF ROOT CAUSE FAULTS IN COMPLEX NETWORK AND IT SYSTEMS.

Dr. Yuri Rabover
Co-founder, Director Product Strategy
VMTurbo
Yuri.Rabover@VMTurbo.com
Member of the SMARTS founding team

We are looking for
summer interns!
Please contact Yuri
←

WHAT IS IT ALL ABOUT?

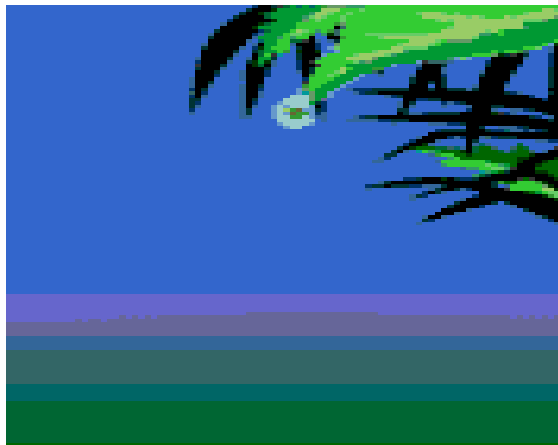

IN SEARCH OF ROOT CAUSE....



BACKGROUND

- Smarts: **S**ystem **M**anagement **ARTS**
 - Founded in 1993 as a network management R&D lab
 - Patented the leading correlation technology
 - Built a software platform and solutions to leverage it
- Thousands of customers throughout the world
 - Networks
 - Systems
 - Applications
- Bought by EMC² in 2005 for \$275 mln.
- Yuri joined SMARTS in 1993.



PROBLEM SCENARIO

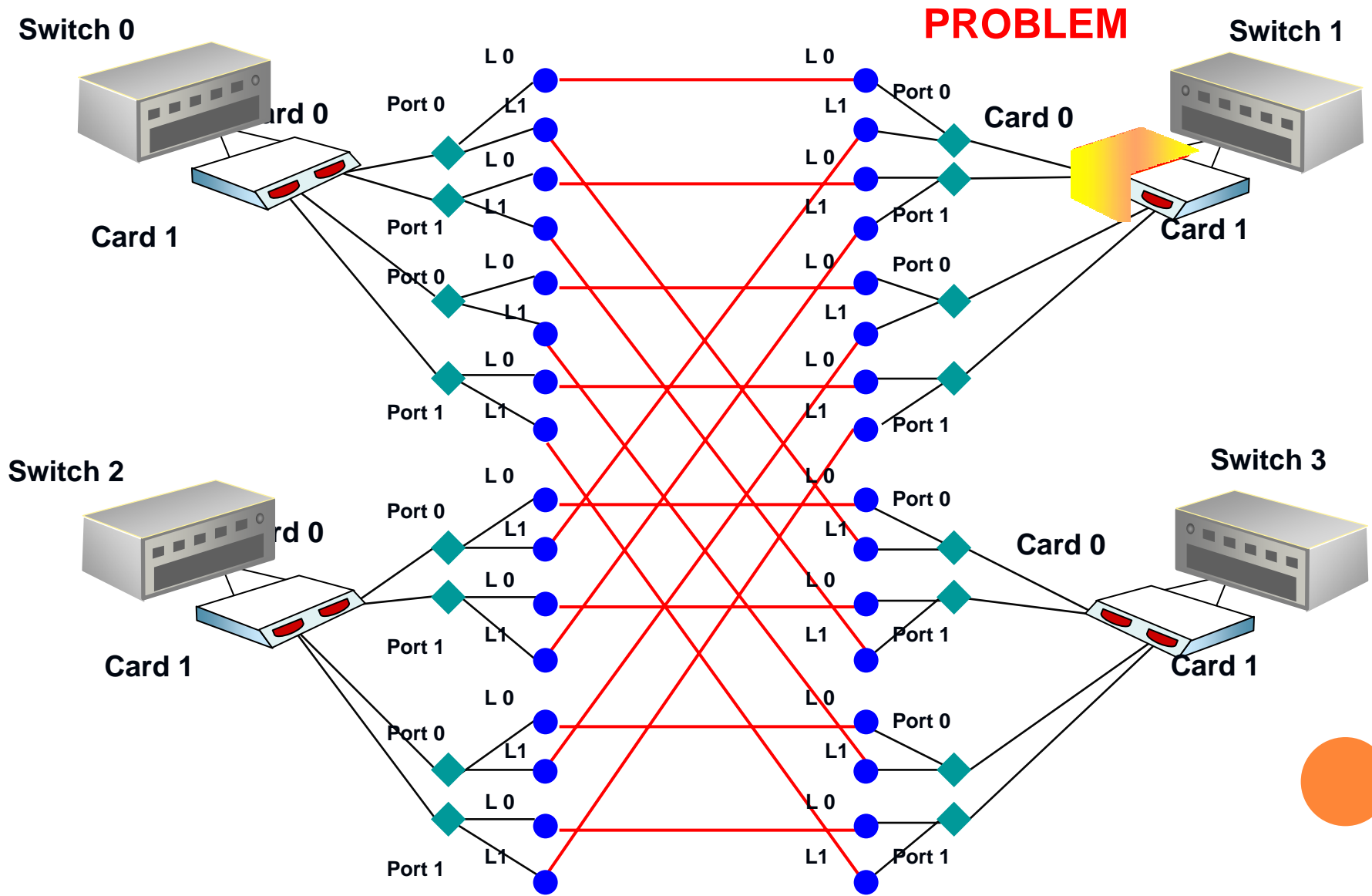

PROBLEM SCENARIO

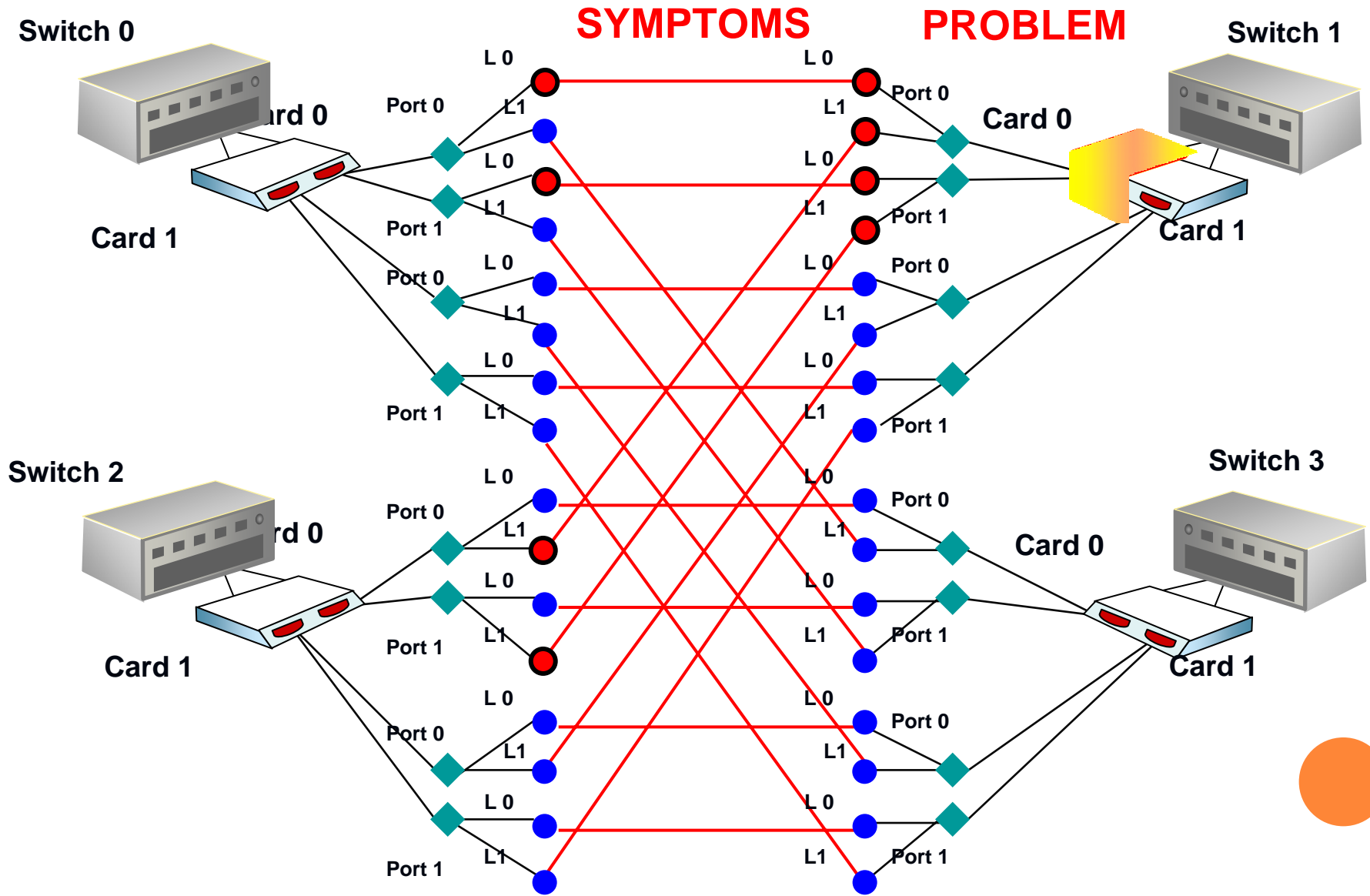

PROBLEM SCENARIO

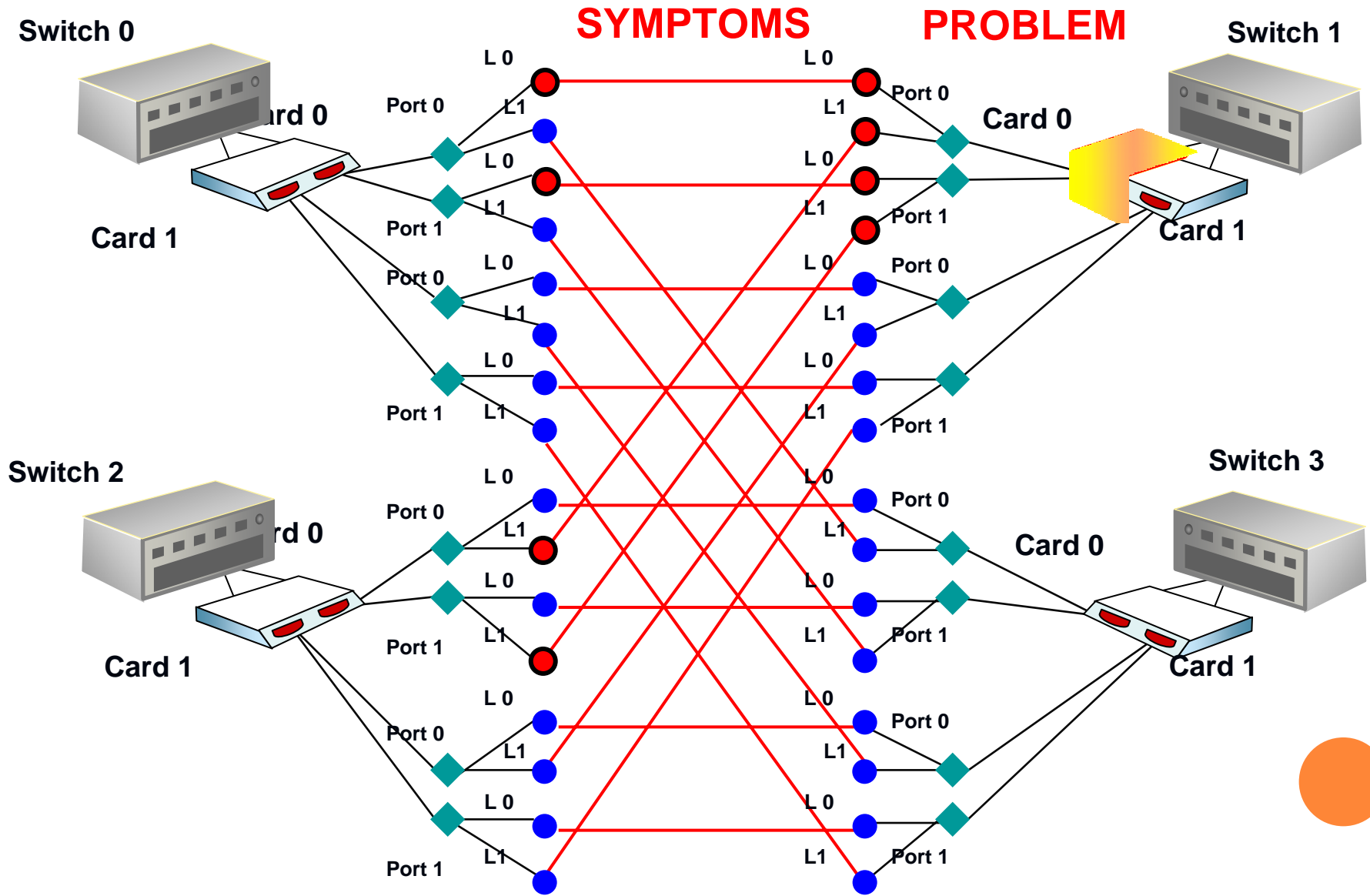

PROBLEM SCENARIO

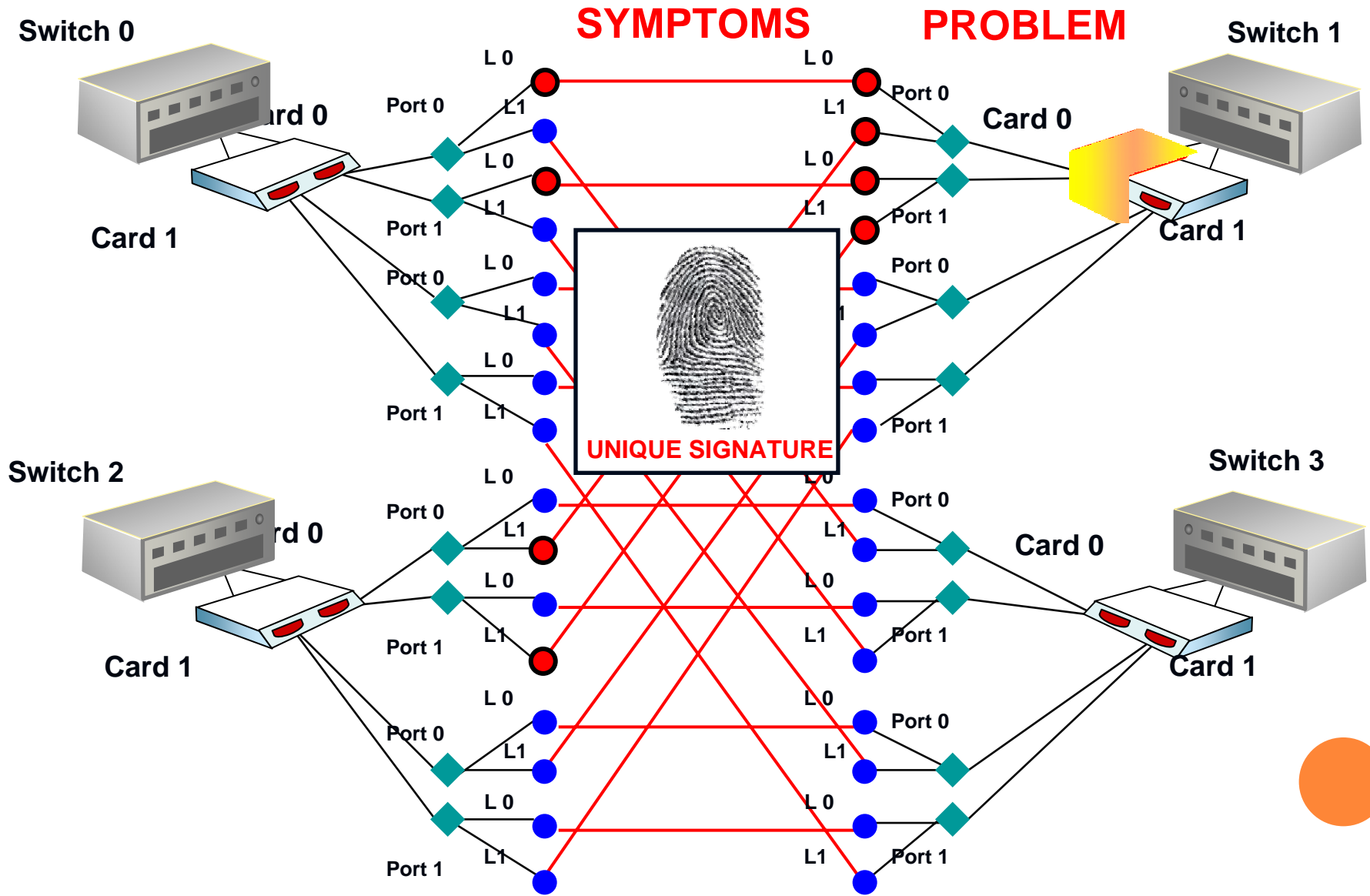

RCA CHALLENGES

- Problems can start in any logical or physical object in the network, attached systems, or applications.
- A single problem often causes many symptoms in many related objects.
- The absence of particular symptoms is as meaningful as the presence of particular symptoms.
- Different problems can cause many overlapping symptoms. For example, the operationally down status of logical port 0 over physical port 1 in Card 0 of Switch 1 could be caused by a failure in any one of the following components:
 - Switch 1
 - Switch 1 Card 0
 - Switch 1 Card 0 Port 1
 - Switch 1 Card 0 Port 1 Logical Port 1
 - Switch 2
 - Switch 2 Card 0
 - Switch 2 Card 0 Port 1
 - Switch 2 Card 0 Port 1 Logical Port 1
 - The trunk connecting Port 1 in Card 0 in Switch 1 with Port 1 in Card 0 in Switch 2.



RCA CHALLENGES – CONT.

- Symptoms can propagate across related components. In our example, a symptom propagated from a card to its ports and from a port to a peer port. This makes it necessary to examine *all the symptoms* across related elements in order to identify the root cause.
- Problems are not always observable in the object where they originate. For example, if the switch does not generate card failure traps, the card failure would have no direct (local) symptoms.
- Problems can occur in objects that do not generate any observable events. For example, there is no event and/or trap associated with a trunk.



CONVENTIONAL APPROACH WRITE RULES

“If all the logical ports that are layered over the physical ports in S1C0 report as operationally down, and all the logical ports that are their peers in connected switches also report as operationally down, then the S1C0 failure is the root-cause problem generating all these symptoms.”

IF

S1C0P0L0 down AND
S1C0P0L1 down AND
S1C0P1L0 down AND
S1C0P1L1 down AND
S0C0P0L0 down AND
S0C0P1L0 down AND
S2C0P0L1 down AND
S2C0P1L1 down

THEN CONCLUDE S1C0 failure



CONVENTIONAL APPROACH DOWNSTREAM SUPPRESSION

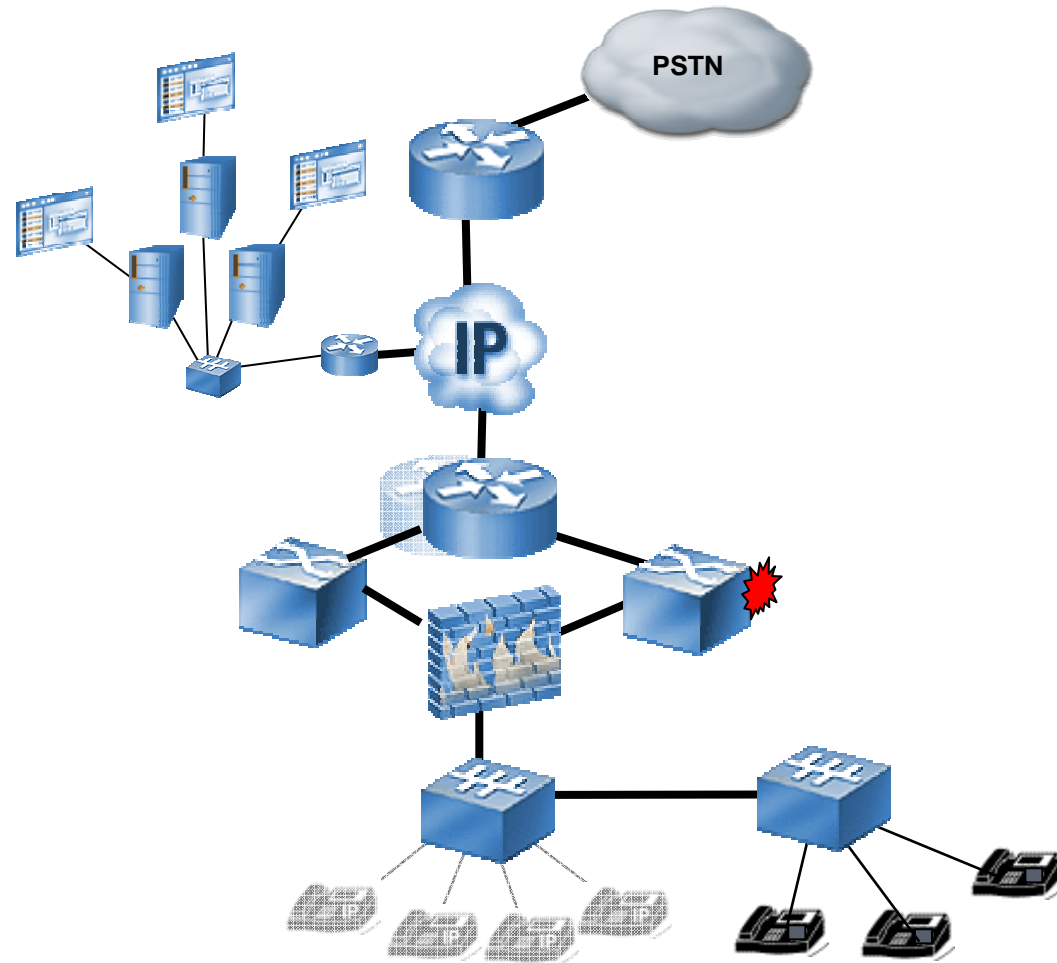

CONVENTIONAL APPROACHES

difficult to separate
symptoms from root-cause
problems

manual problem diagnosis

rules-based “models”

change outpaces rules writing

significant expertise and time

silo management—no

correlation across

technology silos

multiple groups chasing the same problem

need the whole view to isolate faults



“Sea of red”

*Rules-Based Management puts the burden of analysis
on IT **BUDGETS***



WHAT'S MISSING?

Display

Modeling

Analysis

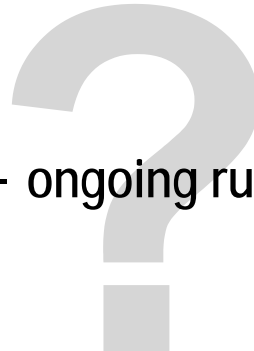

No built-in analysis — ongoing rules-writing required

Data & Event Collection

Applications Databases Servers Firewalls IDS
Routers Switches Telephony Video Storage Optical



MODELING VS ROOT CAUSE ANALYSIS

- Modeling uses a top-down approach:
 - Starting from the problems to be diagnosed
 - Problem: the battery is dead
 - Moving to the symptoms caused by the problem
 - Symptom: the car does not start
- Root cause analysis uses abduction
 - Starting from the symptoms observed
 - Symptom: the car does not start
 - Infer the root cause
 - Problem: the battery is dead

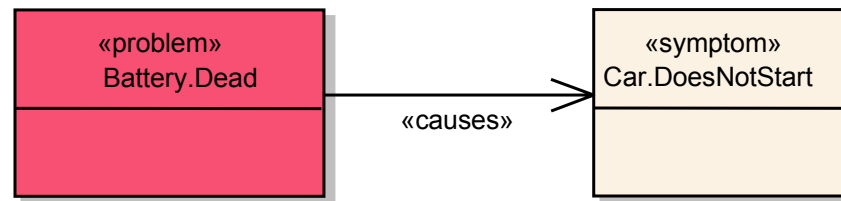

Modeling

Analysis



ROOT CAUSE ANALYSIS – PROBLEM DEFINITION

- Wikipedia:
 - Root cause analysis (RCA) is a class of problem solving methods aimed at identifying the root causes of problems or events.
- Smarts:
 - Given a set of symptoms, find the problem, or the set of problems, that best explains those symptoms.

Smarts:

Given a set of symptoms, find the set of problems that best explains those symptoms.

Causal Network Model of a Technology Object

- **Causation C** – relation from P to S associating individual problems and symptoms.

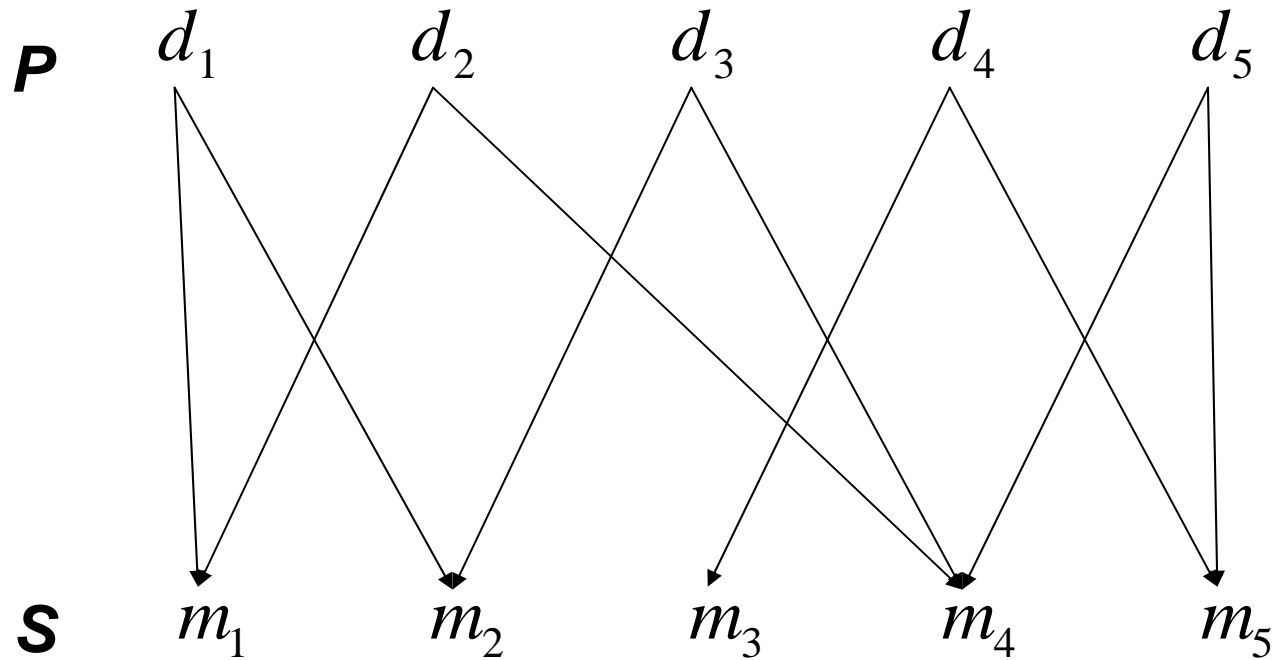

BOTTOM-UP APPROACH TO ROOT-CAUSE ANALYSIS

- Q. What are the symptoms available to me?
- Q. What can I make out of these symptoms?



TOP-DOWN APPROACH TO ROOT-CAUSE ANALYSIS

- Q. What problems do I want to be able to diagnose?
- Q. Which symptoms are manifested by those problems
 - And what is the minimum set of symptoms needed to uniquely diagnose each problem?

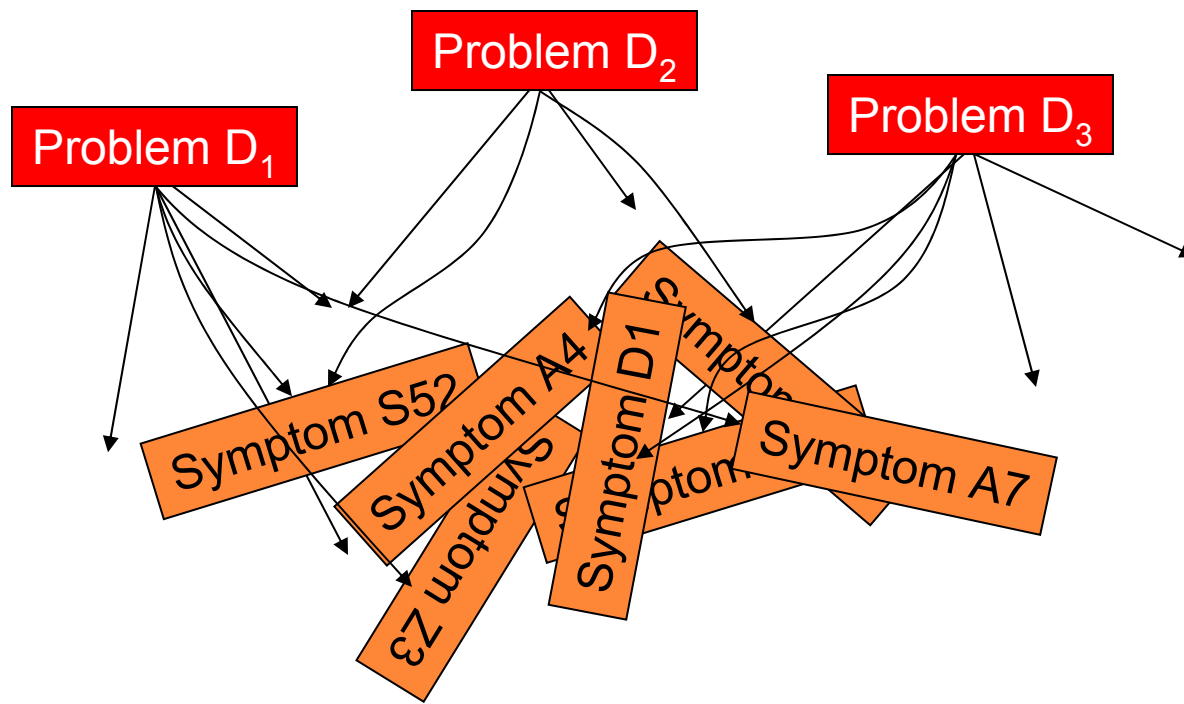

REMINDER

- Entia non sunt multiplicanda praeter necessitatem.
- The simplest explanation is usually the best.
- The simplest explanation Considers the minimum set of symptoms to support each possible explanation.
- The law of parsimony plays a major role in resource management.
- Don't collect all available symptoms, only those relevant to the problems diagnosed.



EMC SMARTS TECHNOLOGIES: BEHAVIOR MODELS

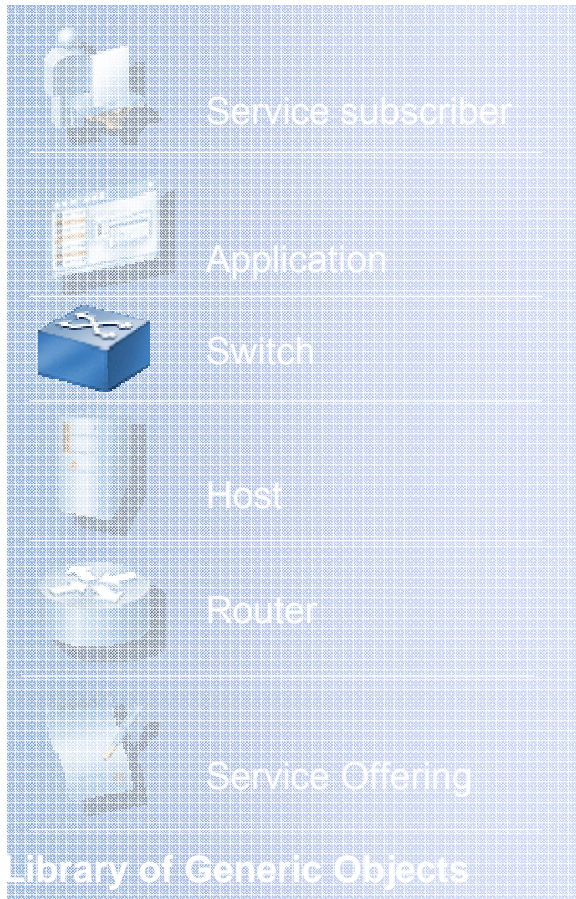

PROBLEMS

Codebook

| | s0 | s1 | s2 | s3 | s4 | s5 | s6 | s7 | s8 | s9 | s10 | s11 | s12 | s13 | s14 | s15 | s16 | s17 | s18 | s19 | s20 | s21 | s22 | s23 | s24 | s25 | s26 | s27 | s28 | s29 | s30 | s31 | | | |
|------------|----|----|----|----|----|----|----|----|----|----|-----|-----|-----|-----|-----|-----|-----|-----|-----|-----|-----|-----|-----|-----|-----|-----|-----|-----|-----|-----|-----|-----|--|--|--|
| symptom010 | | | | | | | | | | | | | | | | | | | | | | | | | | | | | | | | | | | |
| symptom010 | | | | | | | | | | | | | | | | | | | | | | | | | | | | | | | | | | | |
| symptom010 | | | | | | | | | | | | | | | | | | | | | | | | | | | | | | | | | | | |
| symptom010 | | | | | | | | | | | | | | | | | | | | | | | | | | | | | | | | | | | |
| symptom010 | | | | | | | | | | | | | | | | | | | | | | | | | | | | | | | | | | | |
| symptom010 | | | | | | | | | | | | | | | | | | | | | | | | | | | | | | | | | | | |
| symptom010 | | | | | | | | | | | | | | | | | | | | | | | | | | | | | | | | | | | |
| symptom010 | | | | | | | | | | | | | | | | | | | | | | | | | | | | | | | | | | | |
| symptom010 | | | | | | | | | | | | | | | | | | | | | | | | | | | | | | | | | | | |
| symptom010 | | | | | | | | | | | | | | | | | | | | | | | | | | | | | | | | | | | |
| symptom010 | | | | | | | | | | | | | | | | | | | | | | | | | | | | | | | | | | | |
| symptom010 | | | | | | | | | | | | | | | | | | | | | | | | | | | | | | | | | | | |
| symptom010 | | | | | | | | | | | | | | | | | | | | | | | | | | | | | | | | | | | |
| symptom010 | | | | | | | | | | | | | | | | | | | | | | | | | | | | | | | | | | | |
| symptom010 | | | | | | | | | | | | | | | | | | | | | | | | | | | | | | | | | | | |
| symptom010 | | | | | | | | | | | | | | | | | | | | | | | | | | | | | | | | | | | |
| symptom010 | | | | | | | | | | | | | | | | | | | | | | | | | | | | | | | | | | | |
| symptom010 | | | | | | | | | | | | | | | | | | | | | | | | | | | | | | | | | | | |
| symptom010 | | | | | | | | | | | | | | | | | | | | | | | | | | | | | | | | | | | |
| symptom010 | | | | | | | | | | | | | | | | | | | | | | | | | | | | | | | | | | | |
| symptom010 | | | | | | | | | | | | | | | | | | | | | | | | | | | | | | | | | | | |
| symptom010 | | | | | | | | | | | | | | | | | | | | | | | | | | | | | | | | | | | |
| symptom010 | | | | | | | | | | | | | | | | | | | | | | | | | | | | | | | | | | | |
| symptom010 | | | | | | | | | | | | | | | | | | | | | | | | | | | | | | | | | | | |
| symptom010 | | | | | | | | | | | | | | | | | | | | | | | | | | | | | | | | | | | |
| symptom010 | | | | | | | | | | | | | | | | | | | | | | | | | | | | | | | | | | | |
| symptom010 | | | | | | | | | | | | | | | | | | | | | | | | | | | | | | | | | | | |
| symptom010 | | | | | | | | | | | | | | | | | | | | | | | | | | | | | | | | | | | |
| symptom010 | | | | | | | | | | | | | | | | | | | | | | | | | | | | | | | | | | | |
| symptom010 | | | | | | | | | | | | | | | | | | | | | | | | | | | | | | | | | | | |
| symptom010 | | | | | | | | | | | | | | | | | | | | | | | | | | | | | | | | | | | |
| symptom010 | | | | | | | | | | | | | | | | | | | | | | | | | | | | | | | | | | | |
| symptom010 | | | | | | | | | | | | | | | | | | | | | | | | | | | | | | | | | | | |
| symptom010 | | | | | | | | | | | | | | | | | | | | | | | | | | | | | | | | | | | |
| symptom010 | | | | | | | | | | | | | | | | | | | | | | | | | | | | | | | | | | | |
| symptom010 | | | | | | | | | | | | | | | | | | | | | | | | | | | | | | | | | | | |
| symptom010 | | | | | | | | | | | | | | | | | | | | | | | | | | | | | | | | | | | |
| symptom010 | | | | | | | | | | | | | | | | | | | | | | | | | | | | | | | | | | | |
| symptom010 | | | | | | | | | | | | | | | | | | | | | | | | | | | | | | | | | | | |
| symptom010 | | | | | | | | | | | | | | | | | | | | | | | | | | | | | | | | | | | |
| symptom010 | | | | | | | | | | | | | | | | | | | | | | | | | | | | | | | | | | | |
| symptom010 | | | | | | | | | | | | | | | | | | | | | | | | | | | | | | | | | | | |
| symptom010 | | | | | | | | | | | | | | | | | | | | | | | | | | | | | | | | | | | |
| symptom010 | | | | | | | | | | | | | | | | | | | | | | | | | | | | | | | | | | | |
| symptom010 | | | | | | | | | | | | | | | | | | | | | | | | | | | | | | | | | | | |
| symptom010 | | | | | | | | | | | | | | | | | | | | | | | | | | | | | | | | | | | |
| symptom010 | | | | | | | | | | | | | | | | | | | | | | | | | | | | | | | | | | | |
| symptom010 | | | | | | | | | | | | | | | | | | | | | | | | | | | | | | | | | | | |
| symptom010 | | | | | | | | | | | | | | | | | | | | | | | | | | | | | | | | | | | |
| symptom010 | | | | | | | | | | | | | | | | | | | | | | | | | | | | | | | | | | | |
| symptom010 | | | | | | | | | | | | | | | | | | | | | | | | | | | | | | | | | | | |
| symptom010 | | | | | | | | | | | | | | | | | | | | | | | | | | | | | | | | | | | |
| symptom010 | | | | | | | | | | | | | | | | | | | | | | | | | | | | | | | | | | | |
| symptom010 | | | | | | | | | | | | | | | | | | | | | | | | | | | | | | | | | | | |
| symptom010 | | | | | | | | | | | | | | | | | | | | | | | | | | | | | | | | | | | |
| symptom010 | | | | | | | | | | | | | | | | | | | | | | | | | | | | | | | | | | | |
| symptom010 | | | | | | | | | | | | | | | | | | | | | | | | | | | | | | | | | | | |
| symptom010 | | | | | | | | | | | | | | | | | | | | | | | | | | | | | | | | | | | |
| symptom010 | | | | | | | | | | | | | | | | | | | | | | | | | | | | | | | | | | | |
| symptom010 | | | | | | | | | | | | | | | | | | | | | | | | | | | | | | | | | | | |
| symptom010 | | | | | | | | | | | | | | | | | | | | | | | | | | | | | | | | | | | |
| symptom010 | | | | | | | | | | | | | | | | | | | | | | | | | | | | | | | | | | | |
| symptom010 | | | | | | | | | | | | | | | | | | | | | | | | | | | | | | | | | | | |
| symptom010 | | | | | | | | | | | | | | | | | | | | | | | | | | | | | | | | | | | |
| symptom010 | | | | | | | | | | | | | | | | | | | | | | | | | | | | | | | | | | | |
| symptom010 | | | | | | | | | | | | | | | | | | | | | | | | | | | | | | | | | | | |
| symptom010 | | | | | | | | | | | | | | | | | | | | | | | | | | | | | | | | | | | |
| symptom010 | | | | | | | | | | | | | | | | | | | | | | | | | | | | | | | | | | | |
| symptom010 | | | | | | | | | | | | | | | | | | | | | | | | | | | | | | | | | | | |
| symptom010 | | | | | | | | | | | | | | | | | | | | | | | | | | | | | | | | | | | |
| symptom010 | | | | | | | | | | | | | | | | | | | | | | | | | | | | | | | | | | | |
| symptom010 | | | | | | | | | | | | | | | | | | | | | | | | | | | | | | | | | | | |
| symptom010 | | | | | | | | | | | | | | | | | | | | | | | | | | | | | | | | | | | |
| symptom010 | | | | | | | | | | | | | | | | | | | | | | | | | | | | | | | | | | | |
| symptom010 | | | | | | | | | | | | | | | | | | | | | | | | | | | | | | | | | | | |
| symptom010 | | | | | | | | | | | | | | | | | | | | | | | | | | | | | | | | | | | |
| symptom010 | | | | | | | | | | | | | | | | | | | | | | | | | | | | | | | | | | | |

EMC SMARTS TECHNOLOGIES: BEHAVIOR MODELS

○ Logical Port

- **Problem Down** Causes *OperationallyDown, ConnectedPortDown*
Local symptom *OperationallyDown*
Propagated symptom *ConnectedPortDown to Connected Logical Ports Down*

• Physical Port

- **Problem Down** Causes *PortDown*
Propagated symptom *PortDown To Logical Ports Layered over the Port are Down*
Propagated symptom *ConnectedPortDown to Layered over Logical Ports*

• Card

- **Problem Down** Causes *PortDown*
Propagated symptom *PortDown To Physical Ports in the Card are Down*
Propagated symptom *ConnectedPortDown to Physical Ports in the Card*

• Switch

- **Problem Down** Causes *ConnectedPortDown*
Propagated symptom *ConnectedPortDown to Cards in the Switch*

EMC SMARTS TECHNOLOGIES: SWITCH 0 CARD 0 SYMPTOMS

Switch 0 **PROBLEM**

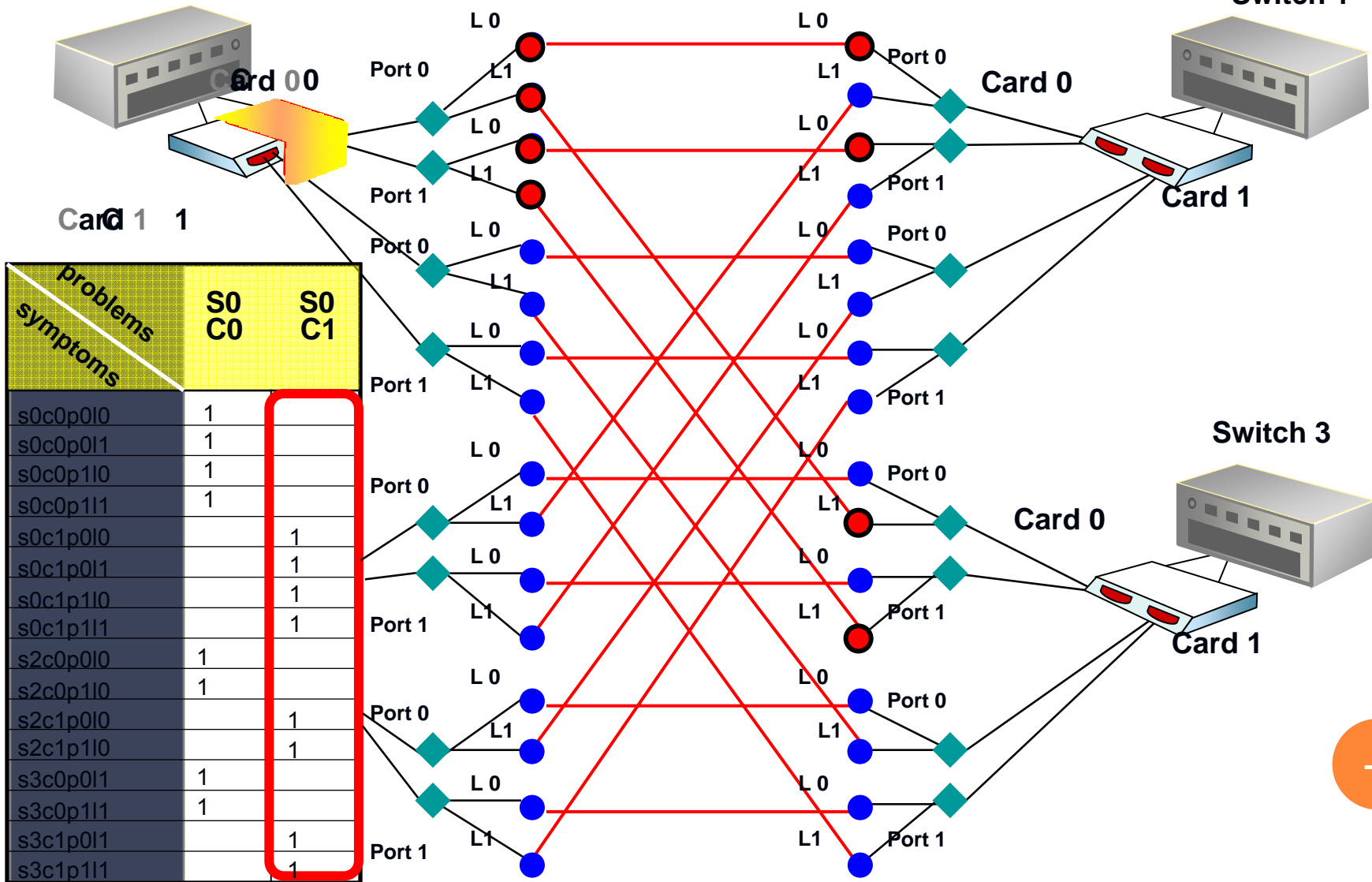

EMC SMARTS TECHNOLOGIES: CODEBOOK & PROBLEM SIGNATURES

SYMPTOMS

PROBLEMS

Symptoms Observed in Environment



| | s0 | s1 | s2 | s3 | s0 c0 | s0 c1 | s1 c0 | s1 c1 | s2 c0 | s2 c1 | s3 c0 | s3 c1 | s0 c0 p0 | s0 c0 p1 | s0 c1 p0 | s0 c1 p1 | s1 c0 p0 | s1 c0 p1 | s1 c1 p0 | s1 c1 p1 | s2 c0 p0 | s2 c0 p1 | s2 c1 p0 | s2 c1 p1 | s3 c0 p0 | s3 c0 p1 | s3 c1 p0 | s3 c1 p1 | |
|----------|----|----|----|----|----------|----------|----------|----------|----------|----------|----------|----------|----------------|----------------|----------------|----------------|----------------|----------------|----------------|----------------|----------------|----------------|----------------|----------------|----------------|----------------|----------------|----------------|---|
| s0c0p0i0 | | 1 | | | 1 | | 1 | | | | | | 1 | | | | 1 | | | | | | | | | | | | |
| s0c0p0i1 | | | | 1 | 1 | | | | | | 1 | | 1 | | | | | | | | | | | | | 1 | | | |
| s0c0p1i0 | | 1 | | | 1 | | 1 | | | | | | | 1 | | | | 1 | | | | | | | | | | | |
| s0c0p1i1 | | | | 1 | 1 | | | | | | 1 | | | 1 | | | | | | | | | | | | | 1 | | |
| s0c1p0i0 | | 1 | | | | 1 | | 1 | | | | | | | 1 | | | | 1 | | | | | | | | | | |
| s0c1p0i1 | | | | 1 | | 1 | | | | | | 1 | | | 1 | | | | | | | | | | | | | 1 | |
| s0c1p1i0 | | 1 | | | | 1 | | 1 | | | | | | | | 1 | | | | 1 | | | | | | | | | |
| s0c1p1i1 | | | | 1 | | 1 | | | | | | 1 | | | | 1 | | | | | | | | | | | | | 1 |
| s1c0p0i0 | 1 | | | | 1 | | 1 | | | | | | 1 | | | | 1 | | | | | | | | | | | | |
| s1c0p0i1 | | | 1 | | | | 1 | | 1 | | | | | | | | 1 | | | | | 1 | | | | | | | |
| s1c0p1i0 | 1 | | | | 1 | | 1 | | | | | | | 1 | | | | 1 | | | | | | | | | | | |
| s1c0p1i1 | | | 1 | | | | 1 | | 1 | | | | | | | | | 1 | | | | | 1 | | | | | | |
| s1c1p0i0 | 1 | | | | | 1 | | 1 | | | | | | | 1 | | | | 1 | | | | | | | | | | |
| s1c1p0i1 | | | 1 | | | | 1 | | 1 | | | | | | | | | | | 1 | | | | | 1 | | | | |
| s1c1p1i0 | 1 | | | | | 1 | | 1 | | | | | | | | 1 | | | | 1 | | | | | | | | | |
| s1c1p1i1 | | | 1 | | | | 1 | | 1 | | | | | | | | | | | 1 | | | | | 1 | | | | |
| s2c0p0i0 | | | | 1 | | | | | 1 | | 1 | | | | | | | | | | 1 | | | | | 1 | | | |
| s2c0p0i1 | | 1 | | | | | 1 | | 1 | | | | | | | 1 | | | | | | 1 | | | | | | | |
| s2c0p1i0 | | | | 1 | | | | | 1 | | 1 | | | | | | | | | | | | 1 | | | | | 1 | |
| s2c0p1i1 | | 1 | | | | | 1 | | 1 | | | | | | | | | | | | | | 1 | | | | | | |
| s2c1p0i0 | | | | 1 | | | | | | 1 | | 1 | | | | | | | | | | | | 1 | | | | 1 | |
| s2c1p0i1 | | 1 | | | | | | | 1 | | 1 | | | | | | | | | 1 | | | | 1 | | | | | |
| s2c1p1i0 | | | | 1 | | | | | | 1 | | 1 | | | | | | | | | | | | 1 | | | | 1 | |
| s2c1p1i1 | | 1 | | | | | | | 1 | | 1 | | | | | | | | | | | | | 1 | | | | 1 | |
| s3c0p0i0 | | | 1 | | | | | | 1 | | 1 | | | | | | | | | | | 1 | | | | 1 | | | |
| s3c0p0i1 | 1 | | | | 1 | | | | | | 1 | | 1 | | | | | | | | | | | | | 1 | | | |
| s3c0p1i0 | | | 1 | | | | | | 1 | | 1 | | | | | | | | | | | | 1 | | | | 1 | | |
| s3c0p1i1 | 1 | | | | 1 | | | | | | 1 | | | 1 | | | | | | | | | | | | | 1 | | |
| s3c1p0i0 | | | 1 | | | | | | | 1 | | 1 | | | | | | | | | | | 1 | | | | | 1 | |
| s3c1p0i1 | 1 | | | | | 1 | | | | | | 1 | | | | 1 | | | | | | | | | | | | 1 | |
| s3c1p1i0 | | | 1 | | | | | | | 1 | | 1 | | | | | | | | | | | | | 1 | | | | 1 |
| s3c1p1i1 | 1 | | | | | 1 | | | | | | 1 | | | | 1 | | | | | | | | | | 1 | | | 1 |

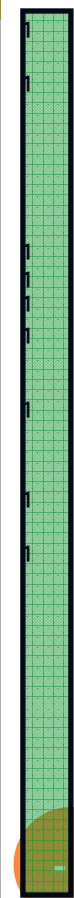

Estimation Algorithm

- Diagnosis problem:

Given binary vector of symptoms Y

Find root cause (codebook column) k

- Solution:

$$k = \arg \min \|Y - B^k\|$$

- B^k is column k of the codebook
- norm denotes Hamming distance



UNFORTUNATELY, NOT THAT SIMPLE

- In a very simple case we can get away with binary symptoms
- In reality symptoms may manifest themselves with some certainty
- What's worse, your data collection is not perfect
 - Symptoms could be lost
 - Symptoms could be misdiagnosed
- The actual analysis algorithm is using a combination of the codebook analysis and abductive inference



ANALYSIS METHODS

- Given:
 - Preconditions α
 - Post conditions β and
 - Rule $R : \alpha \rightarrow \beta$ (α therefore β).
- Induction: Inference of R
 - After numerous examples (evidences) of α and therefore β
 - Induce R
- Deduction: Inference of β
 - Using R , and α
 - Make a conclusion about β ($\alpha \wedge R \vdash \beta$)
- Abduction: Inference of α
 - Using the post condition β and the rule R
 - Infer that the precondition α could explain β ($\beta \wedge R \vdash \alpha$)



ABDUCTION VS. INDUCTION

| Induction | Abduction |
|------------------------------|---------------------------------|
| Hypothesize general rule | Hypothesize specific rule |
| Drawn from many observations | Drawn from a single observation |



ABDUCTION VS. DEDUCTION

| Deduction | Abduction |
|--|---|
| The result is produced for a specific case | The result is produced for a specific case |
| If both rule and case are true then the result is true | Even if both rule and result are true, the inferred specific case is only a possibility |



ROOT CAUSE ANALYSIS IS ACTUALLY ABDUCTION

$R : \alpha \rightarrow \beta$ (α therefore β)

- β are the symptoms
- α are the problems
- R is the causality model: which problems cause the manifestation of which symptoms

SIMPLE EXAMPLE: EVERY PROBLEM CAUSES ONE UNIQUE SYMPTOM

- When symptom β_i is observed, it is clear that problem α_i has occurred
- There is a one-one mapping between symptoms and problems

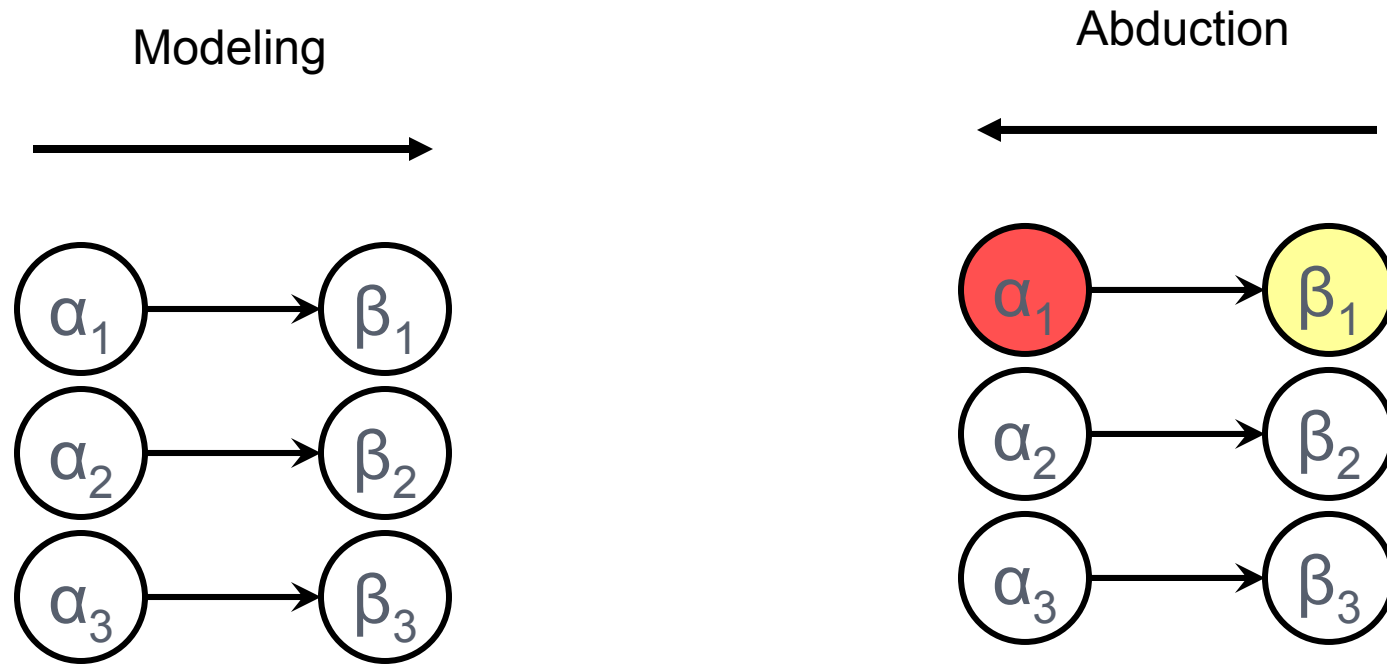

ANOTHER SIMPLE EXAMPLE

- Every problem causes a unique set of symptoms

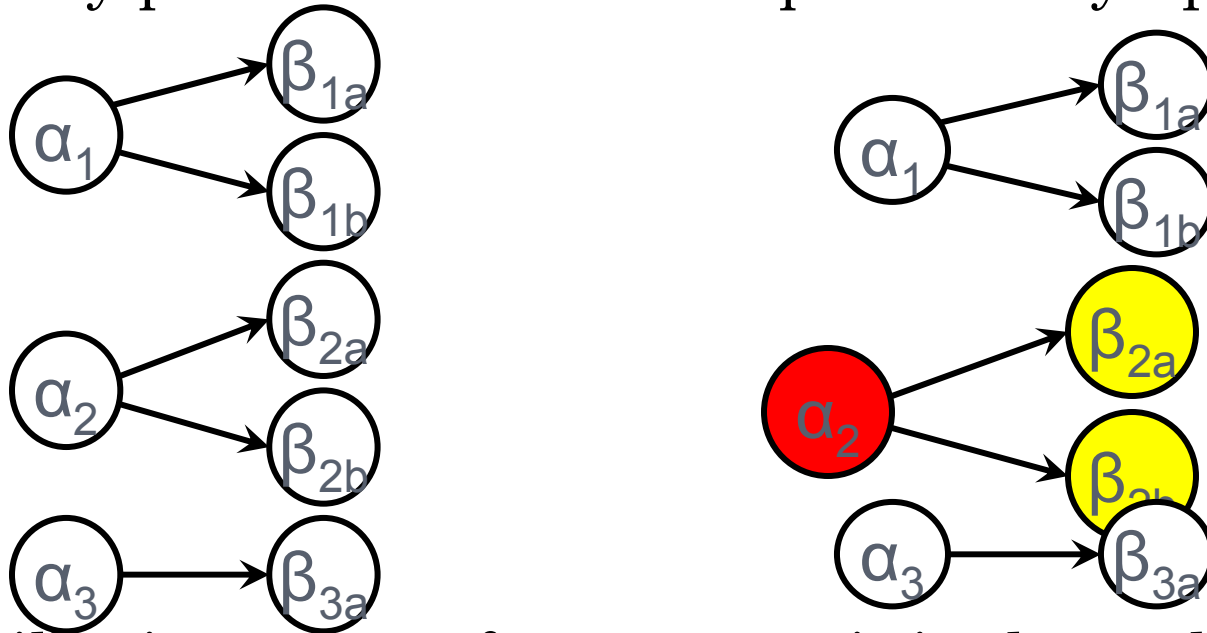

- Still, given a set of symptoms, it is clear which problem has occurred

LET'S COMPLICATE THINGS

- Some symptoms caused by more than one problem

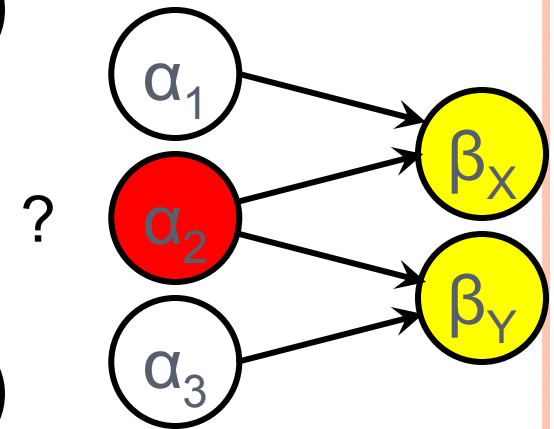
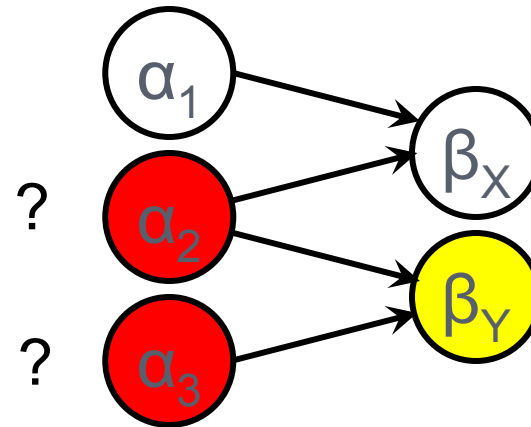
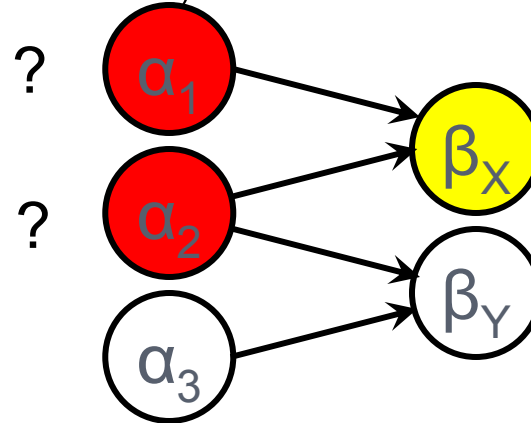
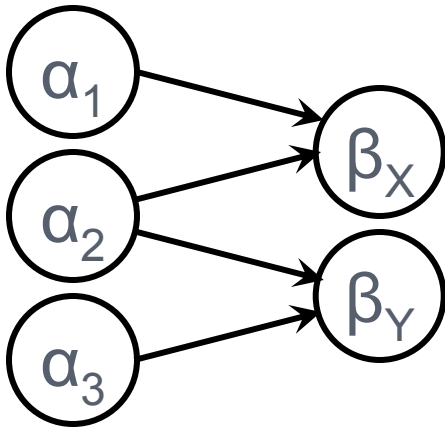

A SPECIFIC EXAMPLE – DIAGNOSING CHICKENPOX

- Chickenpox causes positive result of some blood test and also causes fever
- A Cold causes fever
- Mild chickenpox causes positive blood test but no fever

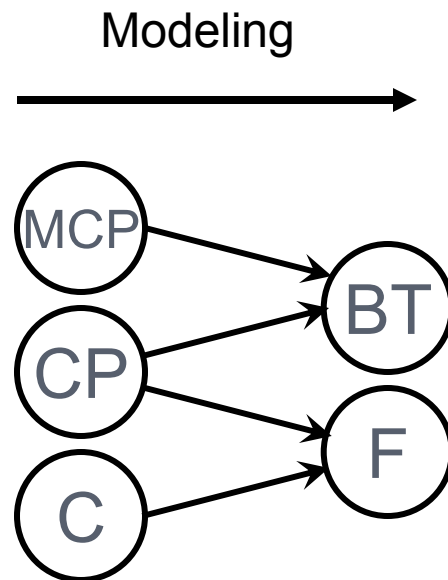

DIAGNOSING CHICKENPOX IN A FLAWLESS ENVIRONMENT

- Case 1: Only fever
⇒ Cold
- Case 2: Fever and blood test is positive
⇒ Chickenpox
- Case 3: Only positive blood test
⇒ Mild Chickpox
- Case 4: No symptoms
⇒ Healthy

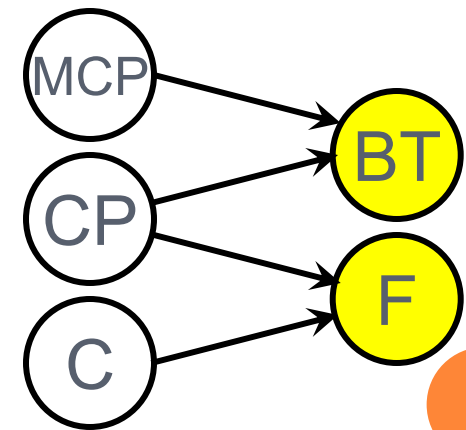

ANOTHER COMPLICATION (OF THE MODEL)

- The blood test is not 100% reliable
 - When you have chickenpox or mild chickenpox, there is a 50% chance that your blood test would turn out positive
 - When you don't have chickenpox or mild chickenpox, there is a 2% chance that your blood test would turn out positive

Remark

BT and F are conditionally independent given CP

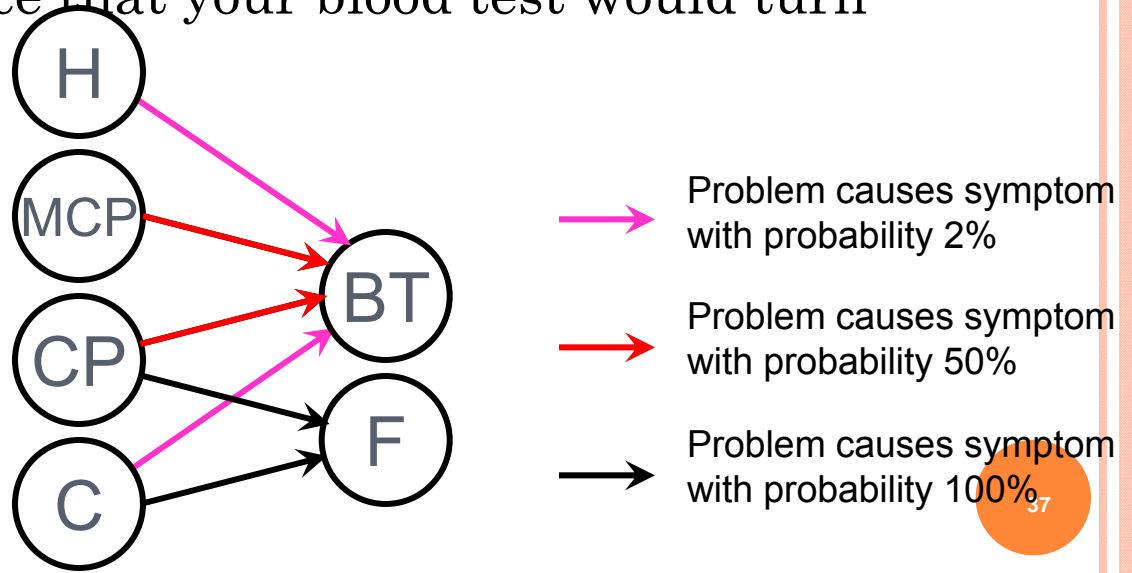

MORE INFORMATION

- Every disease has an a-priori probability
- At any given time, you have a chance of:
 - 0.5% of having chickenpox
 - 1.5% of having mild chickenpox
 - 7% of having a cold
 - 91% of being healthy
- Now apply the principle of parsimony in the abductive reasoning process
- Use Bayes law to calculate the likelihood of each explanation (probability of a disease given symptoms)

BAYES LAW APPLIED TO ABDUCTIVE REASONING

- Given a set of observed symptoms S , what is the probability that a given problem d_i has occurred ?
- Bayes law:

$$P(d_i | S) = P(S | d_i) \times P(d_i) / P(S)$$

The probability that a set of symptoms occurred knowing that the problem d_i occurred

A priori probability of problem d_i

Probability of set of symptoms S .

CHICKENPOX EXAMPLE

$$P(d_i|S) = P(S|d_i) \times P(d_i) / P(S)$$

- Case 2: Fever and blood test is positive

$$P(\text{CP} \mid \text{F} \wedge \text{BT}) = P(\text{F} \wedge \text{BT} \mid \text{CP}) \times P(\text{CP}) / P(\text{F} \wedge \text{BT})$$
$$=$$

$$= P(\text{F} \mid \text{CP}) \times P(\text{BT} \mid \text{CP}) \times P(\text{CP}) / P(\text{F} \wedge \text{BT}) =$$

$$= 100\% \times 50\% \times 0.5\% / P(\text{F} \wedge \text{BT})$$

$$= 0.25\% / P(\text{F} \wedge \text{BT})$$

- Similarly

$$P(\text{MCP} \mid \text{F} \wedge \text{BT}) = 0\% / P(\text{F} \wedge \text{BT})$$

$$P(\text{C} \mid \text{F} \wedge \text{BT}) = 0.14\% / P(\text{F} \wedge \text{BT})$$

$$P(\text{H} \mid \text{F} \wedge \text{BT}) = 0\% / P(\text{F} \wedge \text{BT})$$

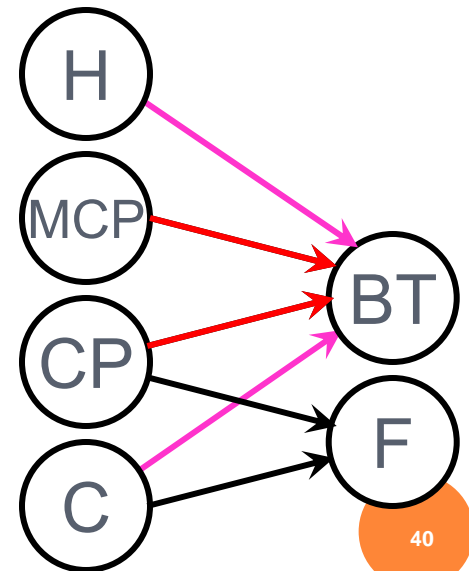

CHICKENPOX EXAMPLE (CONT.)

- Sum of probabilities is 1 :

$$P(\text{CP} \mid F \wedge \text{BT}) + P(\text{MCP} \mid F \wedge \text{BT}) + P(\text{C} \mid F \wedge \text{BT}) + P(\text{H} \mid F \wedge \text{BT}) = 1$$

$$\Rightarrow 0.25\% / P(F \wedge \text{BT}) + 0.14\% / P(F \wedge \text{BT}) = 1$$

$$\Rightarrow P(F \wedge \text{BT}) = 0.39\%$$

$$P(\text{C} \mid F \wedge \text{BT}) = 0.14 / 0.39 = 36\%$$

$$P(\text{CP} \mid F \wedge \text{BT}) = 0.25 / 0.39 = 64\%$$

DIAGNOSING CHICKENPOX AND COLD

- Case 1: fever, blood test negative
 - With probability 96.5% you have a cold
 - With probability 3.5% you have chickenpox
- Case 2: fever, blood test positive
 - With probability 64% you have chickenpox
 - With probability 36% you have a cold
- Case 3: no fever, blood test positive
 - With probability 71% you are healthy
 - With probability 29% you have mild chickenpox
- Case 4: no fever, blood test negative
 - With probability 99% you are healthy
 - With probability 1% you have mild chickenpox

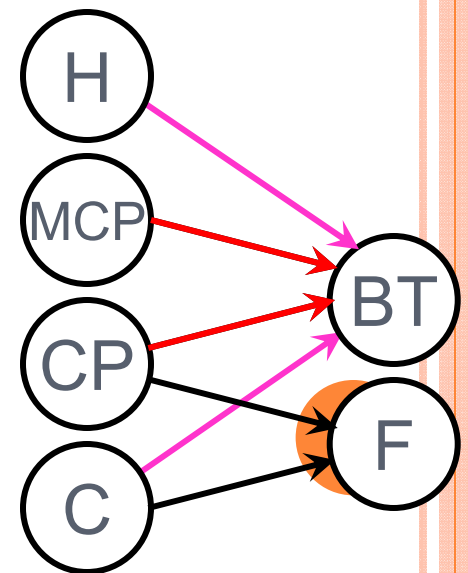

ICIM: THE INCHARGE COMMON INFORMATION MODEL

- Based on DMTF CIM, extended with rich semantics for integrating and automating management applications
- Comprehensive
 - Models network, systems, applications, services, business entities
 - 100+ classes, 50+ relationships
 - Infinitely extensible via inheritance
- Models the complex web of relationships in the real world:
 - Within entities, across entities
- Models cross-domain relationships
 - Key to service management, end-to-end view
 - Pieces together information from heterogeneous sources
- Abstract
 - To scale to networks of unlimited size and complexity through multiple levels of abstraction
 - To decouple management application logic from the specifics of an ever-increasing stream of vendor products
- Efficient
- Open

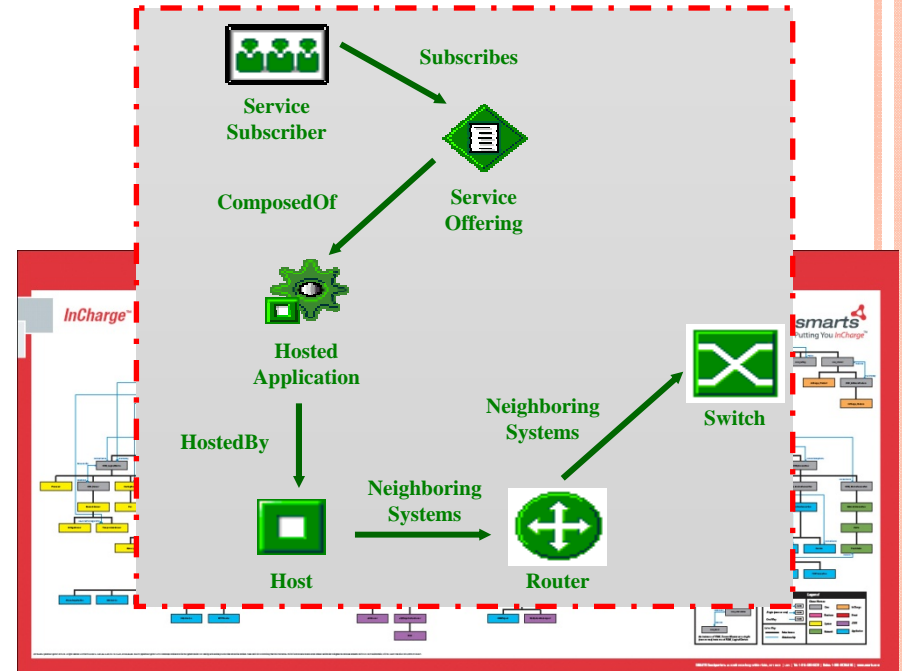

ICIM: THE INCHARGE COMMON INFORMATION MODEL

- Attributes
 - Stored or instrumented – this is transparent to applications
- Relationships
 - 1-1, 1-many, many-1, many-many
- Behaviors
 - Specific extensions for each type of FCAPS application, e.g., problems for fault, constraints for configuration
- Constraints
 - Assure consistency of assigned values, e.g., speed match at both end of a circuit
- MODEL: Managed Object DEfinition Language
 - Based on CORBA IDL syntax

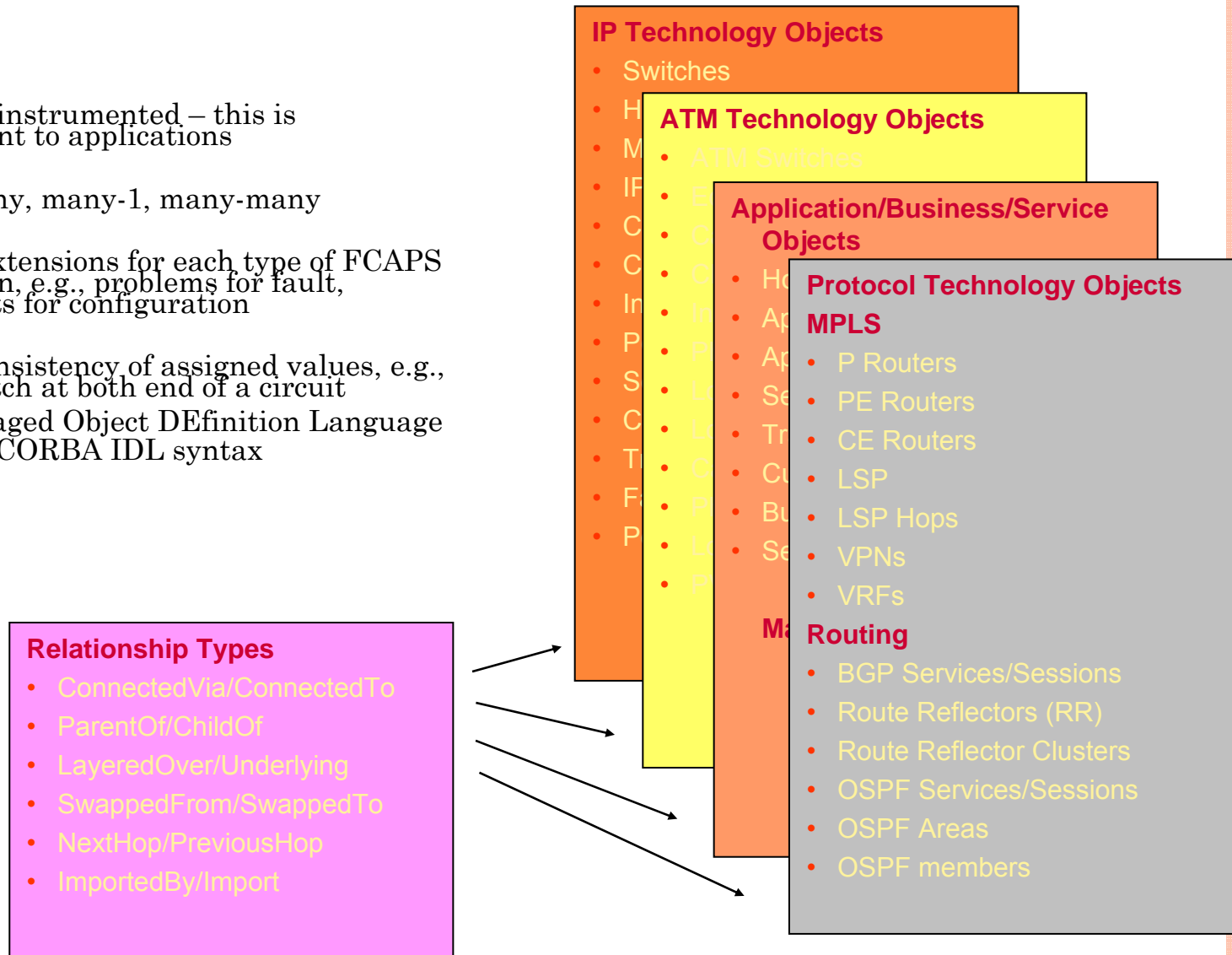

INCHARGE COMMON INFORMATION MODEL

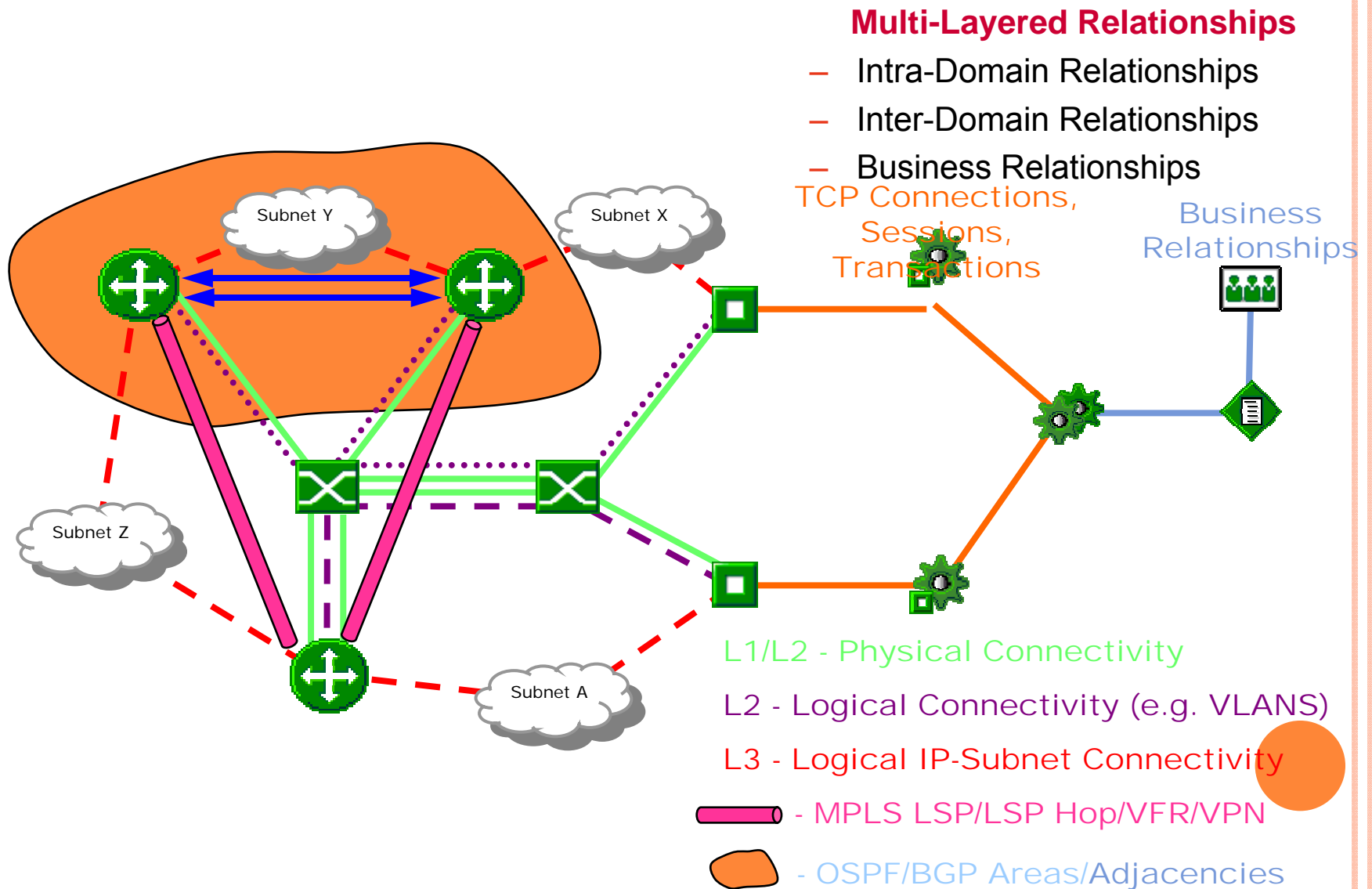



THANK YOU!

Questions, Comments, Suggestions?

And we always in search of good people!

Yuri.Rabover@VMTurbo.com